

Stamping:

Logo LC 10kN SC/M/YY

1. "Logo" ○
2. "LC" load capacity
3. "SC" Supplier code
4. "M" Month code
 - A - January
 - B - February
 - C - March
 - D - April
 - E - May
 - F - June
 - G - July
 - H - August
 - I - September
 - K - October
 - L - November
 - M - December
5. "YY" Year code

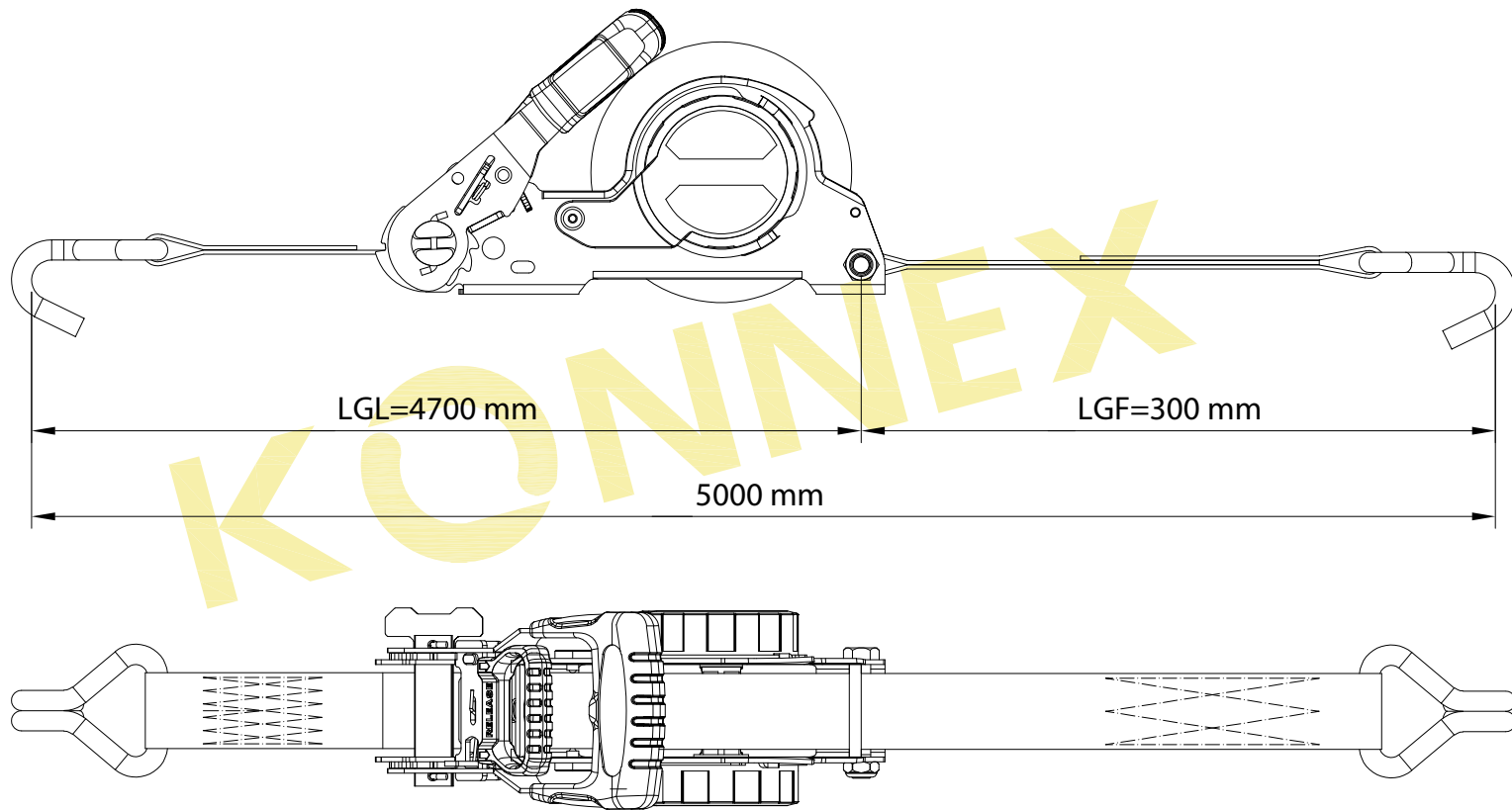

Technical requirements:

1. Breaking strength (BS): 20 kN
2. No cracking pitting rust spot and scratch
3. Tested according: EN ISO 9227 NSS
4. Tested according: DIN EN 12195-2

Product Code:		Surface Requirement:		Tolerance:		Projection:		Scale: ---		Weight: ---g	
8BQ35S030500W000		Zinc plating		---				Material: Steel			
		Date		Name		Part Name:					
		2015.04.08		QWZ		Roll up - System 35mm - 20kN					
		Check				Drawing No: 8BQ35S030500W000					
		Approve									
								Page		Rev	
						Replaces: ---		1		A4	
ECN		No		Content of Change		Date		Name		Original Drawing: ---	
										Replaced by: ---	