

Stamping:

Logo LC 15kN SC/M/YY

1. "Logo" ○
2. "LC" load capacity
3. "SC" Supplier code
4. "M" Month code
 - A - January
 - B - February
 - C - March
 - D - April
 - E - May
 - F - June
 - G - July
 - H - August
 - I - September
 - K - October
 - L - November
 - M - December
5. "YY" Year code

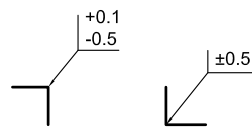
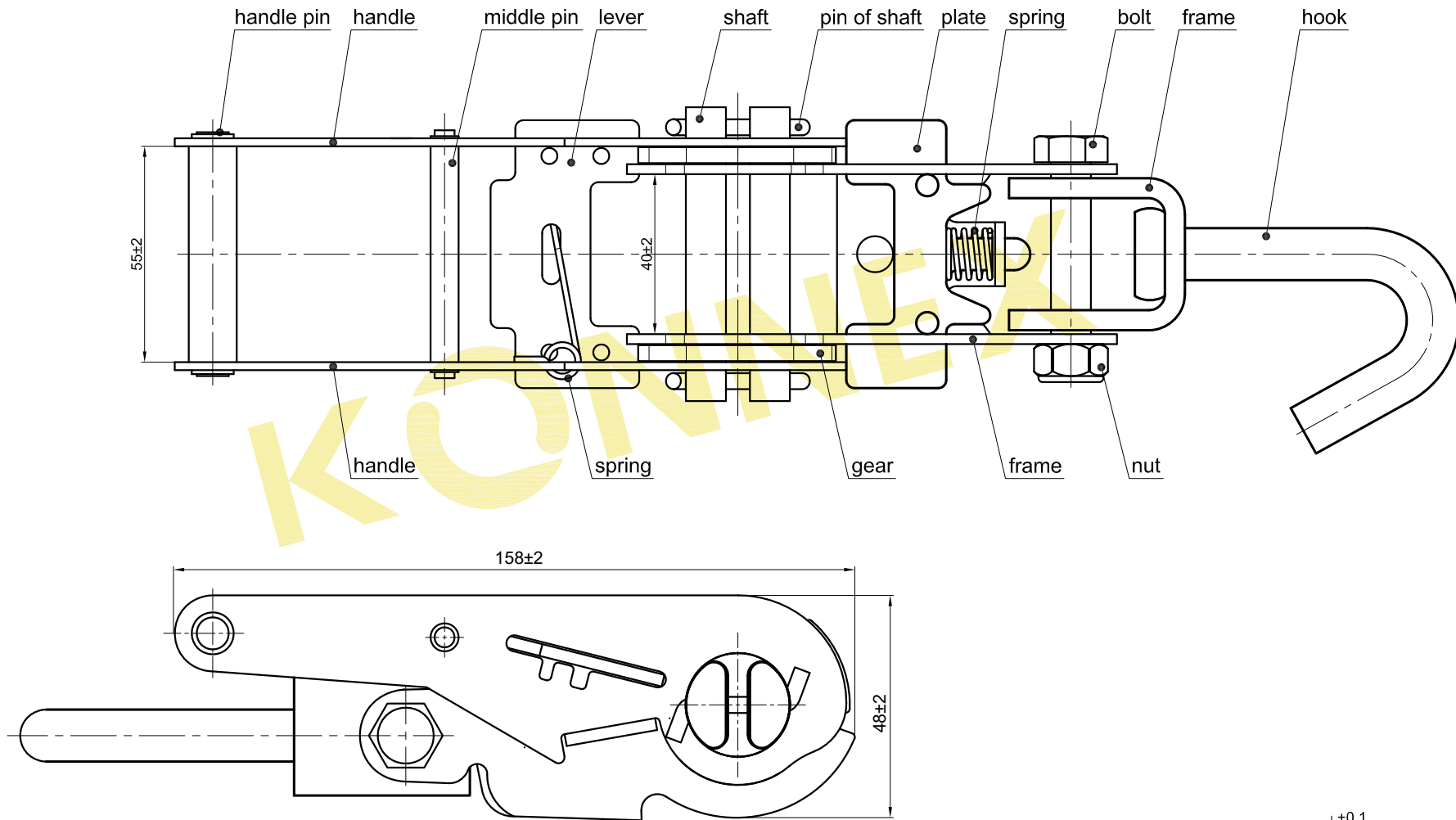

Technical requirements:

1. Breaking strength (BS): 30 kN
2. No cracking pitting rust spot and scratch
3. Tested according: EN ISO 9227 NSS
4. Tested according: DIN EN 12195-2

Product Code: 74BQ001 / 74BD001		Surface Requirement: Zinc plating	Tolerance: ---	Projection: 	Scale: ---	Weight: ---g
				Material: Steel		
		Date 2015.04.08	Name QWZ	Part Name: Druckratsche 35mm - 30kN Pressure ratchet 35mm - 30kN		
		Design		Drawing No: 74BQ001		
		Check				
		Approve				
KONNEX				Replaces: ---		
		ECN	No	Content of Change	Date	Name
		Original Drawing: ---		Replaced by: ---		Page 1
						Rev A4