

Stamping:

Logo LC 50kN SC/M/YY

1. "Logo" ○
2. "LC" load capacity
3. "SC" Supplier code
4. "M" Month code
 - A - January
 - B - February
 - C - March
 - D - April
 - E - May
 - F - June
 - G - July
 - H - August
 - I - September
 - K - October
 - L - November
 - M - December
5. "YY" Year code

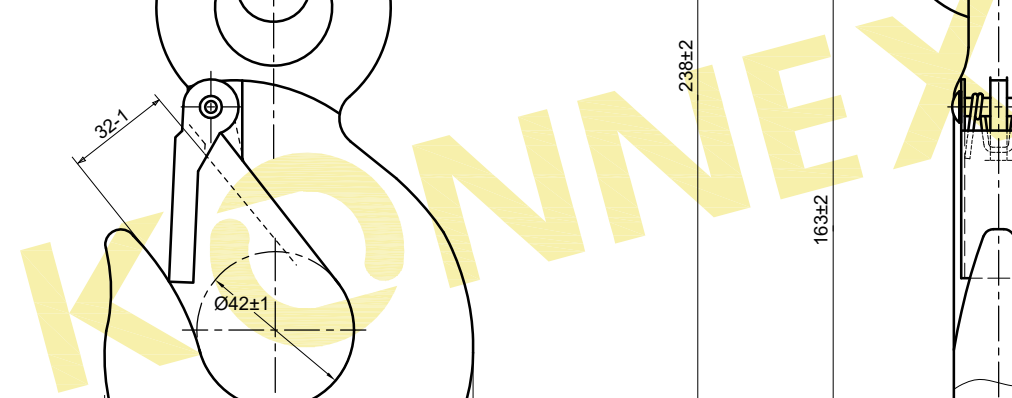
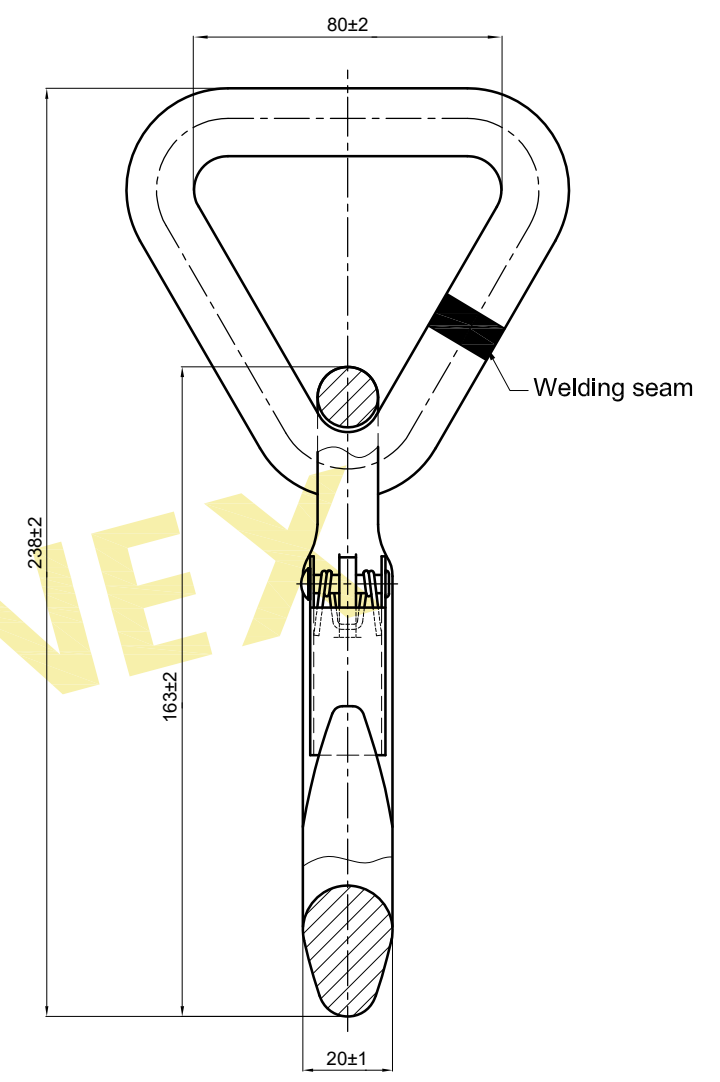
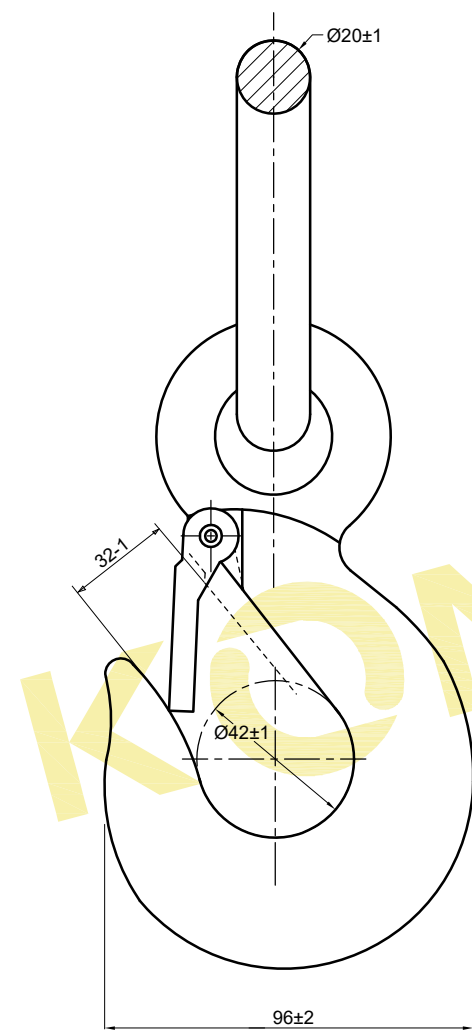

Technical requirements:

1. Breaking strength (BS): 100 kN
2. No cracking pitting rust spot and scratch
3. Tested according: EN ISO 9227 NSS
4. Tested according: DIN EN 12195-2

Product Code: 72DQ003		Surface Requirement: Zinc plating	Tolerance: ---	Projection: 	Scale: ---	Weight: ---g						
		Date 2015.04.08	Name QWZ	Material: Steel								
		Design	Part Name: Karabinerhaken 75mm - 100kN Load hook 75mm - 100kN									
		Check	Drawing No: 72DQ003									
		Approve	<table border="1"> <tr> <td>Page</td> <td>Rev</td> <td>Format</td> </tr> <tr> <td>1</td> <td></td> <td>A4</td> </tr> </table>				Page	Rev	Format	1		A4
Page	Rev	Format										
1		A4										
ECN	No	Content of Change	Date	Name	Original Drawing : ---	Replaces: ---						
					Replaced by: ---							