

**Stamping:**

Logo LC 25kN SC/M/YY

1. "Logo" ○
2. "LC" load capacity
3. "SC" Supplier code
4. "M" Month code
  - A - January
  - B - February
  - C - March
  - D - April
  - E - May
  - F - June
  - G - July
  - H - August
  - I - September
  - K - October
  - L - November
  - M - December
5. "YY" Year code

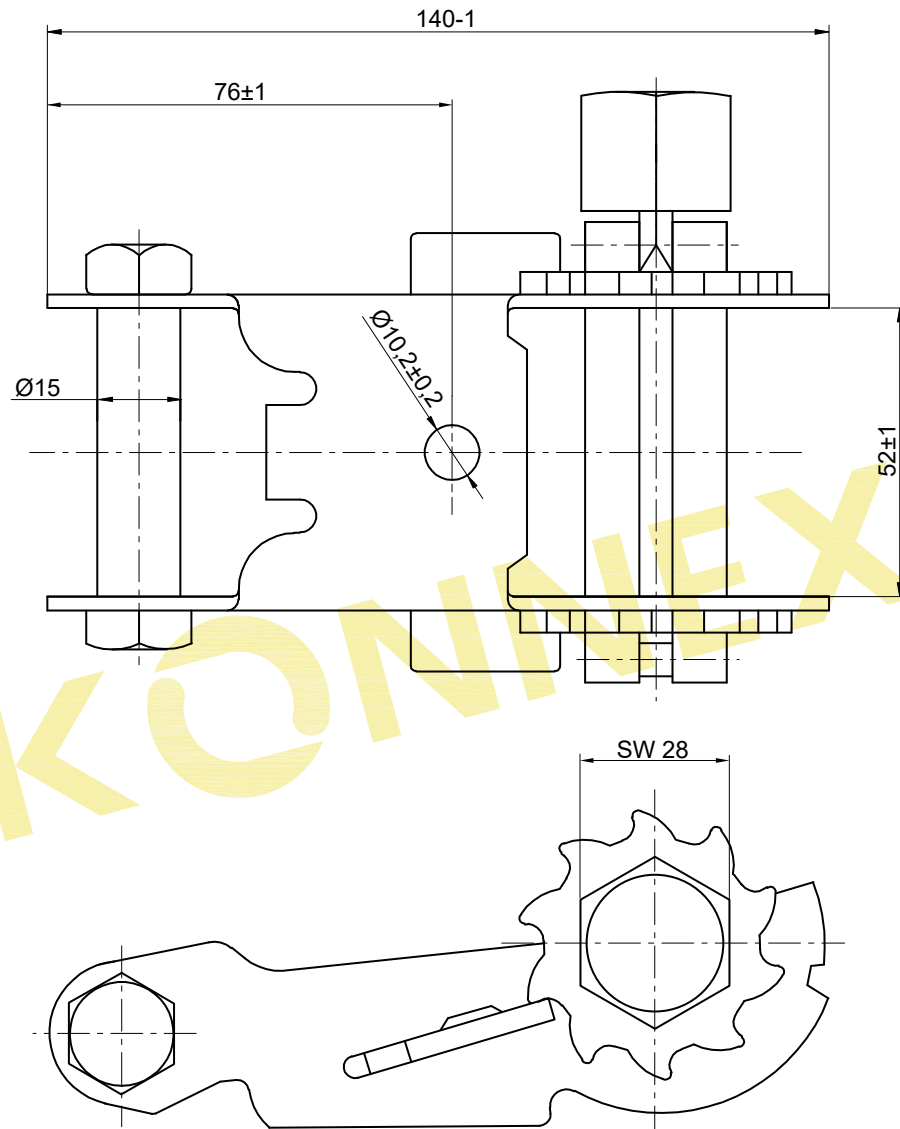

**Technical requirements:**

1. Breaking strength (BS): 50 kN
2. Tested according: EN ISO 9227 NSS
3. Tested according: DIN EN 12195-2

Product Code: <b>72CQ050</b>		Surface Requirement: Zinc plating	Tolerance: ---	Projection: 	Scale: ---	Weight: ---g
		Date 2015.04.08	Name QWZ	Material: Steel		
		Part Name: <b>Druckratschenkörper 50mm - 50kN</b> Pressure ratchet body 50mm - 50kN			Drawing No: <b>72CQ050</b>	
		<b>KONNEX</b>			Page 1	Rev A4
ECN	No	Content of Change	Date	Name	Original Drawing: ---	Replaces: --- Replaced by: ---