

Stamping:

Logo LC 9kN SC/M/YY

1. "Logo" 
2. "LC" load capacity
3. "SC" Supplier code
4. "M" Month code
 - A - January
 - B - February
 - C - March
 - D - April
 - E - May
 - F - June
 - G - July
 - H - August
 - I - September
 - K - October
 - L - November
 - M - December
5. "YY" Year code

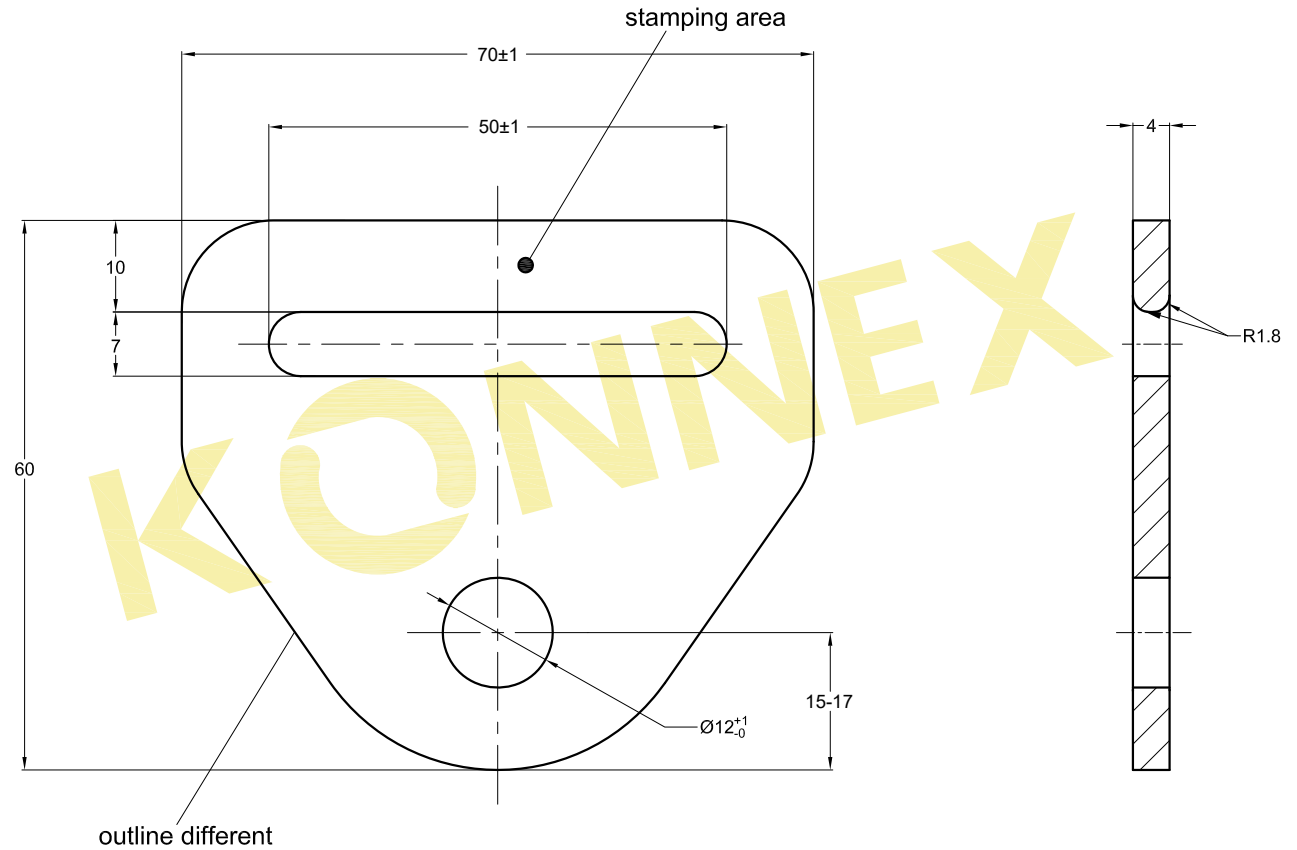

Technical requirements:

1. Breaking strength (BS): 18 kN
2. No cracking pitting rust spot and scratch
3. Tested according: EN ISO 9227 NSS
4. Tested according: DIN EN 12195-2

产品编号: Product Code: 72CQ032		表面要求: Surface Requirement: galvanized		公差等级: Tolerance: ISO2768-m		视图: Projection: 		比例: Scale: 1:1		重量: Weight: 86 g	
						材料: Material: Steel					
						产品名称: Part Name: Endbschlag 50mm - 18kN Buckle 50mm - 18kN					
						图纸编号: Drawing No: 72CQ032					
变更 ECN		序号 No		更改内容 Content of Change		日期 Date		更改人 Name		出图图纸编号: Original Drawing: ---	
		1		Add size		16.07.08		ZRS		替代图号: Replaces: ---	
		2		Tension requirement change		16.09.21		XML		替代批准: Replaced by: ---	
		3		Tension requirement change		17.05.19		XML		替代批准: Replaced by: ---	
						KONNEX CO.,LTD		页码 Page: 1/2		版本 Rev: ---	
								格式 Format: A4			