

**Stamping:**

Logo LC 3,0 kN SC/M/YY

1. "Logo" ○
2. "LC" load capacity
3. "SC" Supplier code
4. "M" Month code
  - A - January
  - B - February
  - C - March
  - D - April
  - E - May
  - F - June
  - G - July
  - H - August
  - I - September
  - K - October
  - L - November
  - M - December
5. "YY" Year code

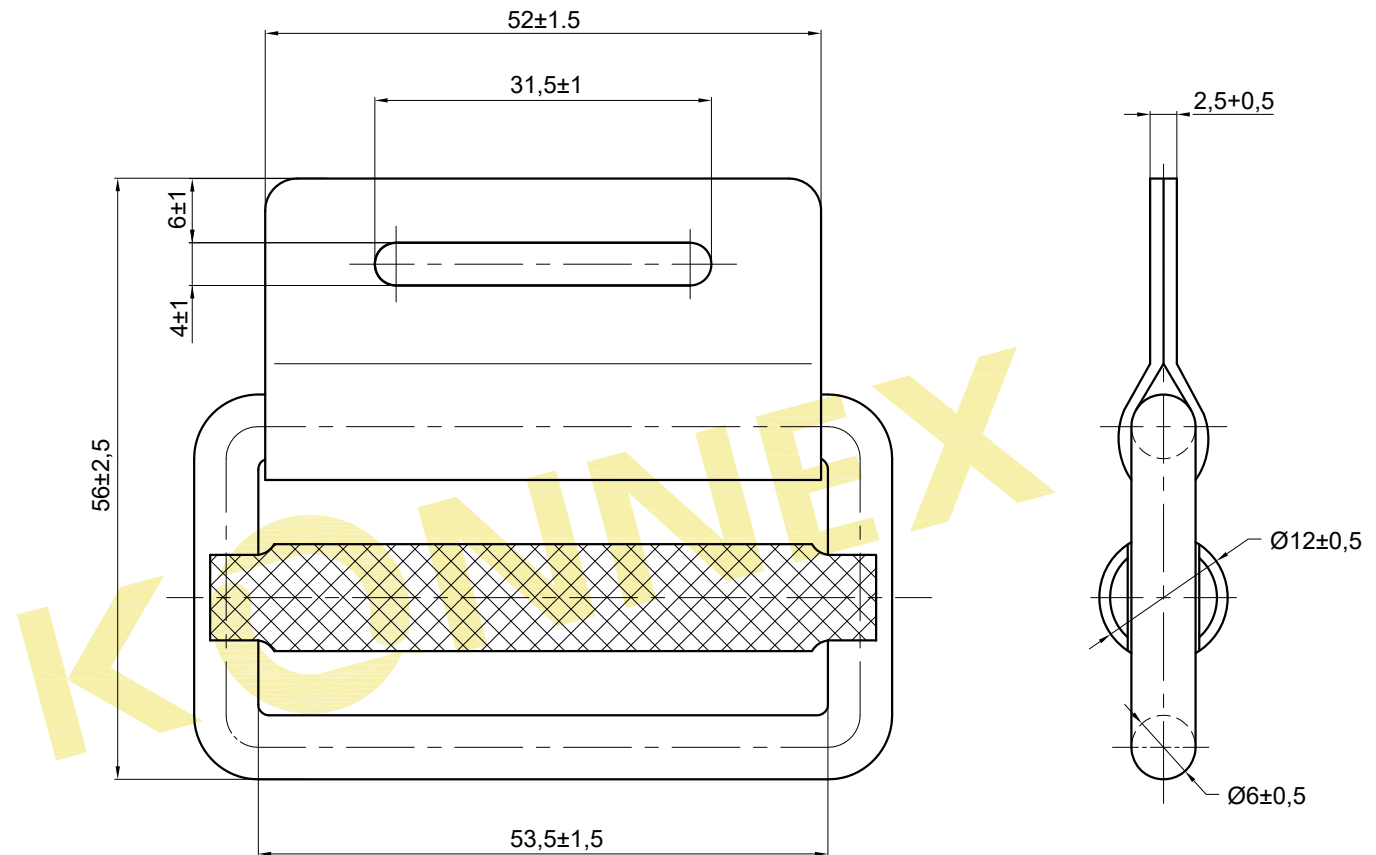

**Technical requirements:**

1. Breaking strength (BS): 6,0 kN
2. Tested according: EN ISO 9227 NSS
3. Tested according: DIN EN 12195-2

Product Code:		Surface Requirement:		Tolerance:		Projection:		Scale: ---		Weight: ---g					
72CQ030		Zinc plating		---				Material: Steel							
		Date		Name		Part Name:									
		2015.04.08		QWZ		Klemmschnalle 50mm - 6,0kN Buckle 50mm - 6,0kN									
		Design													
		Check													
		Approve				Drawing No:									
						72CQ030									
								Page		Rev		Format			
								1				A4			
ECN		No		Content of Change		Date		Name		Original Drawing : ---		Replaces: ---		Replaced by: ---	