

Stamping:

Logo LC 25kN SC/M/YY

1. "Logo" ○
2. "LC" load capacity
3. "SC" Supplier code
4. "M" Month code
 - A - January
 - B - February
 - C - March
 - D - April
 - E - May
 - F - June
 - G - July
 - H - August
 - I - September
 - K - October
 - L - November
 - M - December
5. "YY" Year code

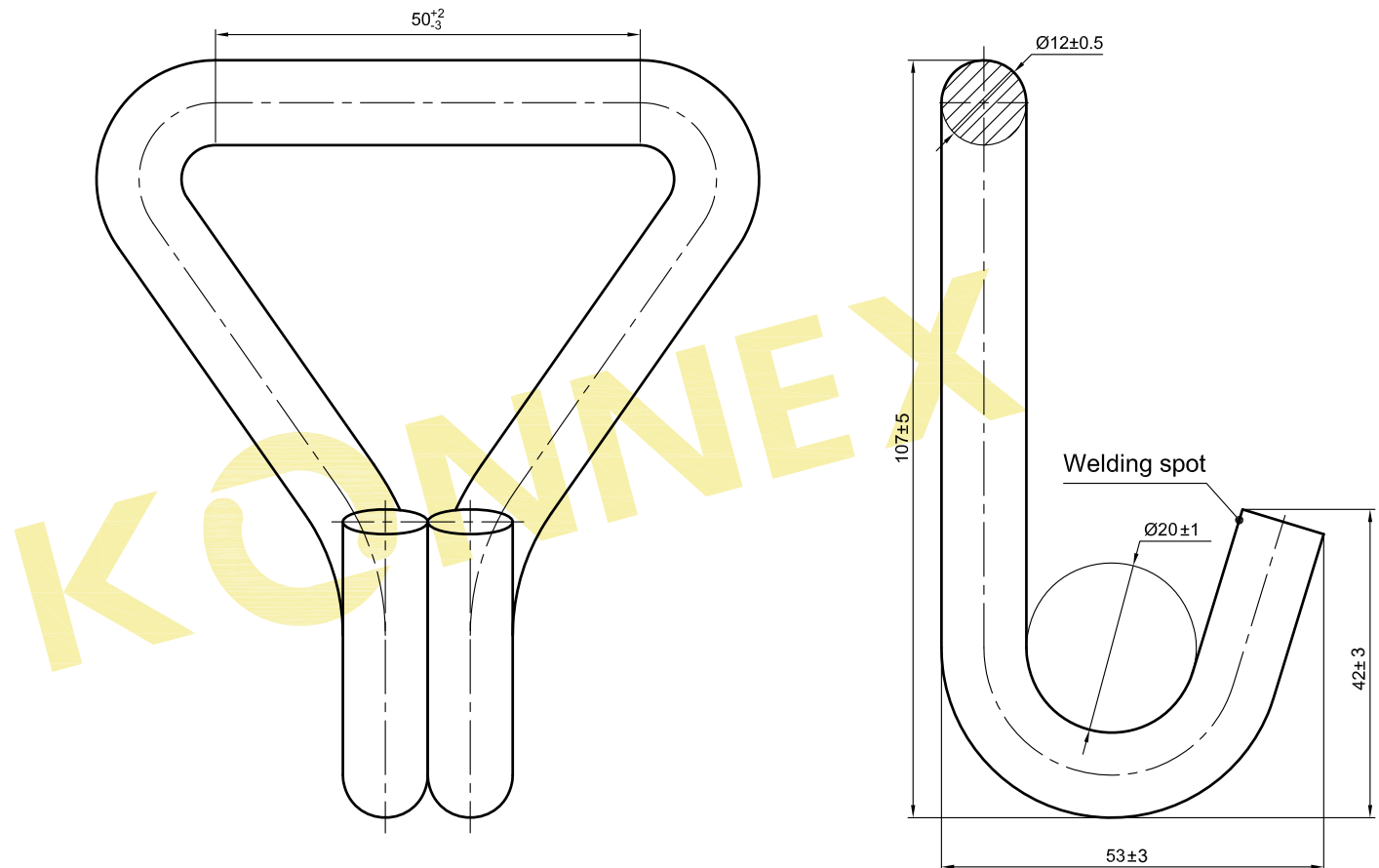

Technical requirements:

1. Breaking strength (BS): 25 kN
2. No cracking pitting rust spot and scratch
3. Tested according: EN ISO 9227 NSS
4. Tested according: DIN EN 12195-2

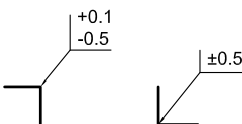

产品编号: Product Code: 72CQ008 72CD008		表面要求: Surface Requirement: Zinc plating	公差等级: Tolerance: ---	视图: Projection: 	比例: Scale: ---	重量: Weight: ---g
		材料: Material: Steel	产品名称: Part Name: Spitzhaken 50mm - 50kN J-Hook 50mm - 50kN			
		图纸编号: Drawing No: 72CQ008	图例: Legend: KONNEX	页码: Page 1	版本: Rev A4	格式: Format A4
变更 ECN	序号 No	更改内容 Content of Change	日期 Date	更改人 Name	出处图纸编号: Original Drawing No: ---	替代图号: Replaces: ---
		日期 / Date		姓名 / Name	替代批准: Replaced by: ---	
		制作 Design	2015.04.08	QWZ		
		校核 Check				
		审核 Approve				