

Stamping:

Logo LC 500 daN SC/M/YY

1. "Logo" ○
2. "LC" load capacity
3. "SC" Supplier code
4. "M" Month code
 - A - January
 - B - February
 - C - March
 - D - April
 - E - May
 - F - June
 - G - July
 - H - August
 - I - September
 - K - October
 - L - November
 - M - December
5. "YY" Year code

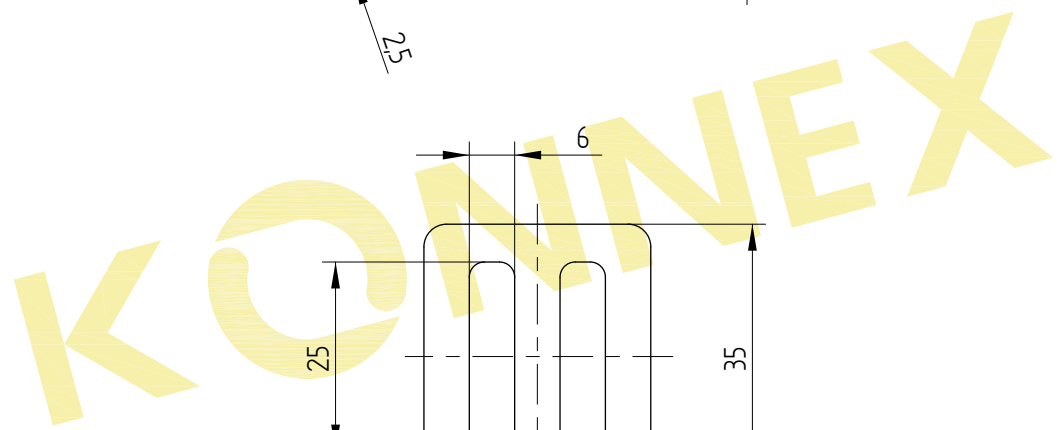
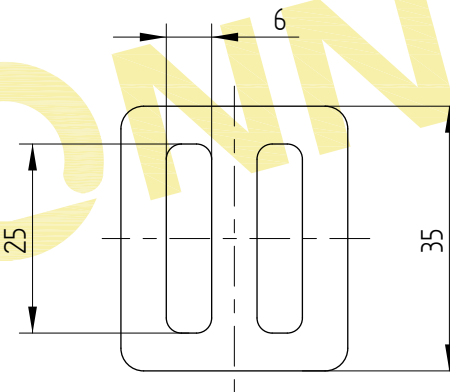
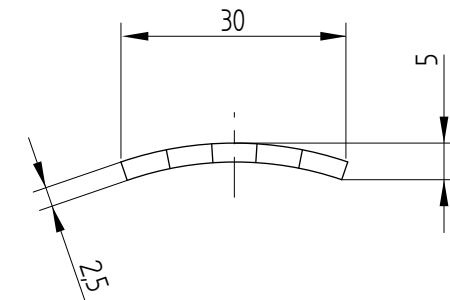

Technical requirements:

1. Breaking strength (BS): 10 kN
2. Tested according: EN ISO 9227 NSS
3. Tested according: DIN EN 12195-2

Product Code: 72AQ021		Surface Requirement: Zinc plating	Tolerance: ---	Projection: 	Scale: ---	Weight: ---g
		Date 2015.04.08	Name QWZ	Material: Steel		
		Design	Part Name: Doppelschnalle 25mm - 10kN Buckle 25mm - 10kN			
		Check	Drawing No: 72AQ021			
		Approve	Page 1 Rev Format A4			
		KONNEX		Replaces: --- Replaced by: ---		
ECN	No	Content of Change	Date	Name	Original Drawing : ---	