

**Stamping:**

Logo LC 5kN SC/M/YY

1. "Logo" ○
2. "LC" load capacity
3. "SC" Supplier code
4. "M" Month code
  - A - January
  - B - February
  - C - March
  - D - April
  - E - May
  - F - June
  - G - July
  - H - August
  - I - September
  - K - October
  - L - November
  - M - December
5. "YY" Year code

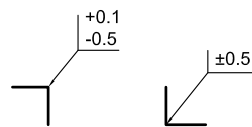
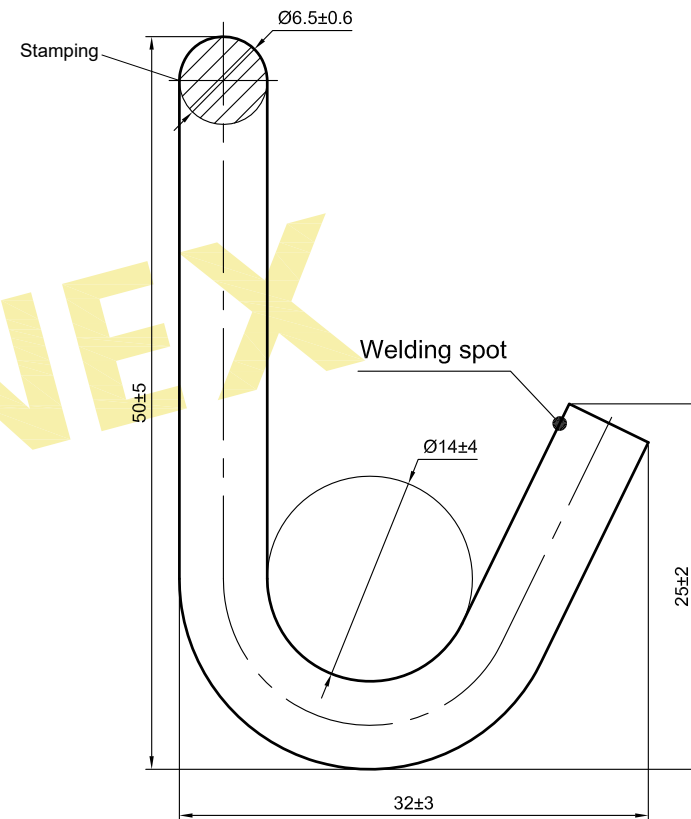
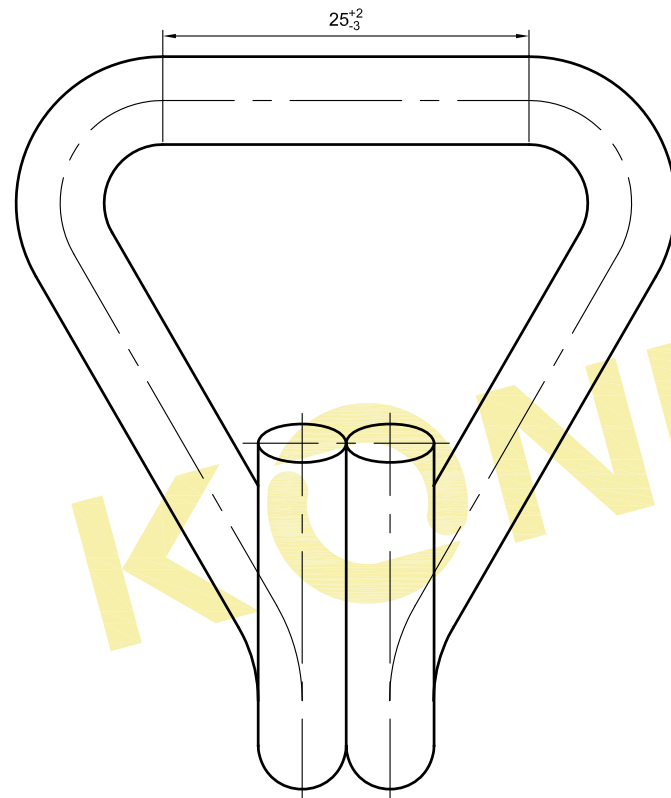

**Technical requirements:**

1. Breaking strength (BS): 10 kN
2. No cracking pitting rust spot and scratch
3. Tested according: EN ISO 9227 NSS (96 h RR)
4. Tested according: DIN EN 12195-2

|                                     |    |                                      |                   |  |                       |               |
|-------------------------------------|----|--------------------------------------|-------------------|--|-----------------------|---------------|
| Product Code:<br>72AQ002<br>72AD002 |    | Surface Requirement:<br>Zinc plating | Tolerance:<br>--- | Projection:<br>                              | Scale: ---            | Weight: ---g  |
|                                     |    |                                      |                   | Material: Steel                              |                       |               |
|                                     |    |                                      |                   | Part Name:                                   |                       |               |
|                                     |    |                                      |                   | Spitzhaken 25mm - 10kN<br>J-Hook 25mm - 10kN |                       |               |
|                                     |    |                                      |                   | Drawing No:                                  |                       |               |
|                                     |    |                                      |                   | 72AQ002                                      |                       |               |
|                                     |    |                                      |                   | Page   | Rev                   | Format        |
|                                     |    |                                      |                   | 1  |                       | A4            |
| ECN                                 | No | Content of Change                    | Date              | Name   | Original Drawing: --- | Replaces: --- |
|                                     |    |                                      |                   |  | Replaced by: ---      |               |