

**Stamping:**

Logo LC 15kN SC/M/YY

1. "Logo" ○
2. "LC" load capacity
3. "SC" Supplier code
4. "M" Month code
  - A - January
  - B - February
  - C - March
  - D - April
  - E - May
  - F - June
  - G - July
  - H - August
  - I - September
  - K - October
  - L - November
  - M - December
5. "YY" Year code

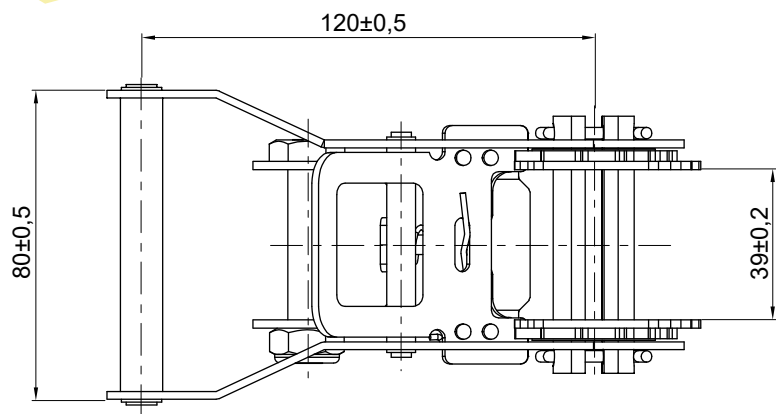
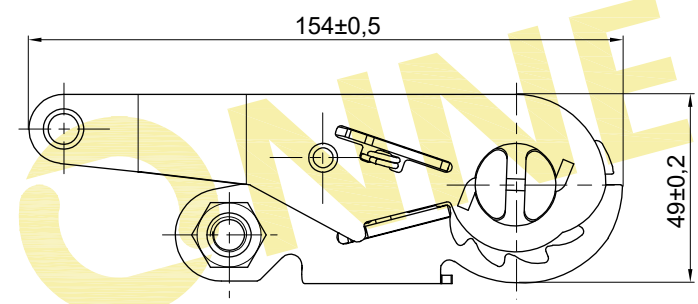
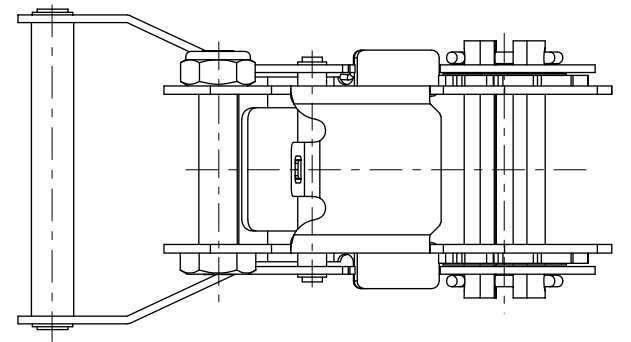

**Technical requirements:**

1. Breaking strength (BS): 30 kN
2. No cracking pitting rust spot and scratch
3. Tested according: EN ISO 9227 NSS
4. Tested according: DIN EN 12195-2

Product Code: 71BQ031		Surface Requirement: Zinc plating	Tolerance: ---	Projection: 	Scale: ---	Weight: ---g
		Date 2015.04.08	Name QWZ	Material: Steel		
		Design	Part Name: Druckratsche 35mm - 30kN Pressure ratchet 35mm - 30kN			
		Check				
		Approve				
		<b>KONNEX</b>		Drawing No: 71BQ031		
				Page 1	Rev	Format A4
ECN	No	Content of Change	Date	Name	Original Drawing: ---	Replaces: --- Replaced by: ---