

Stamping:

Logo LC 15 kN SC/M/YY

1. "Logo" 
2. "LC" load capacity
3. "SC" Supplier code
4. "M" Month code
 - A - January
 - B - February
 - C - March
 - D - April
 - E - May
 - F - June
 - G - July
 - H - August
 - I - September
 - K - October
 - L - November
 - M - December
5. "YY" Year code

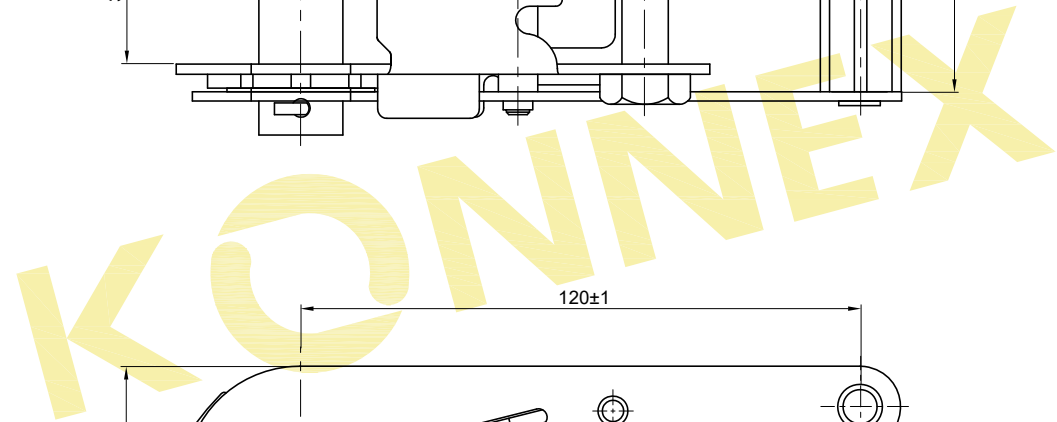
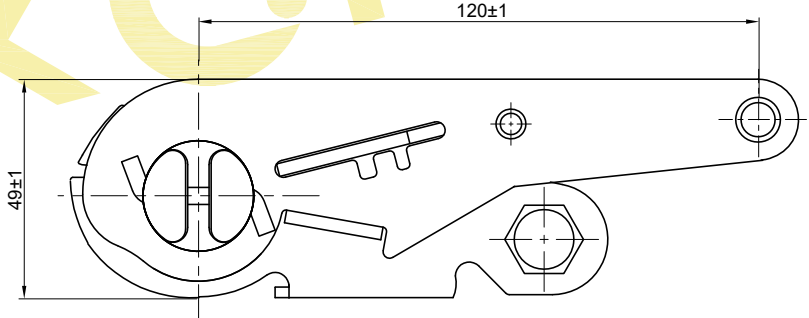
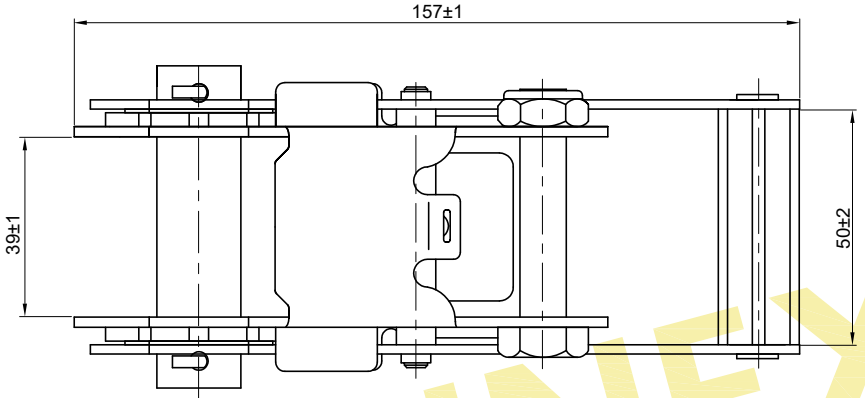

Technical requirements:

1. Breaking strength (BS): 30 kN
2. No cracking pitting rust spot and scratch
3. Tested according: EN ISO 9227 NSS
4. Tested according: DIN EN 12195-2

Product Code: 71BQ030		Surface Requirement: Zinc plating	Tolerance: ---	Projection: 	Scale: ---	Weight: ---g
					Material: Steel	
		Date	Name	Part Name:		
		2015.04.08	QWZ	Druckratsche 35mm - 30kN		
				Pressure ratchet 35mm - 30kN		
				Drawing No:		
				71BQ030		
					Page	Rev
					1	A4
ECN	No	Content of Change	Date	Name	Original Drawing: ---	Replaces: ---
						Replaced by: ---