

Stamping:

Logo LC 5kN SC/M/YY

1. "Logo" ○
2. "LC" load capacity
3. "SC" Supplier code
4. "M" Month code
 - A - January
 - B - February
 - C - March
 - D - April
 - E - May
 - F - June
 - G - July
 - H - August
 - I - September
 - K - October
 - L - November
 - M - December
5. "YY" Year code

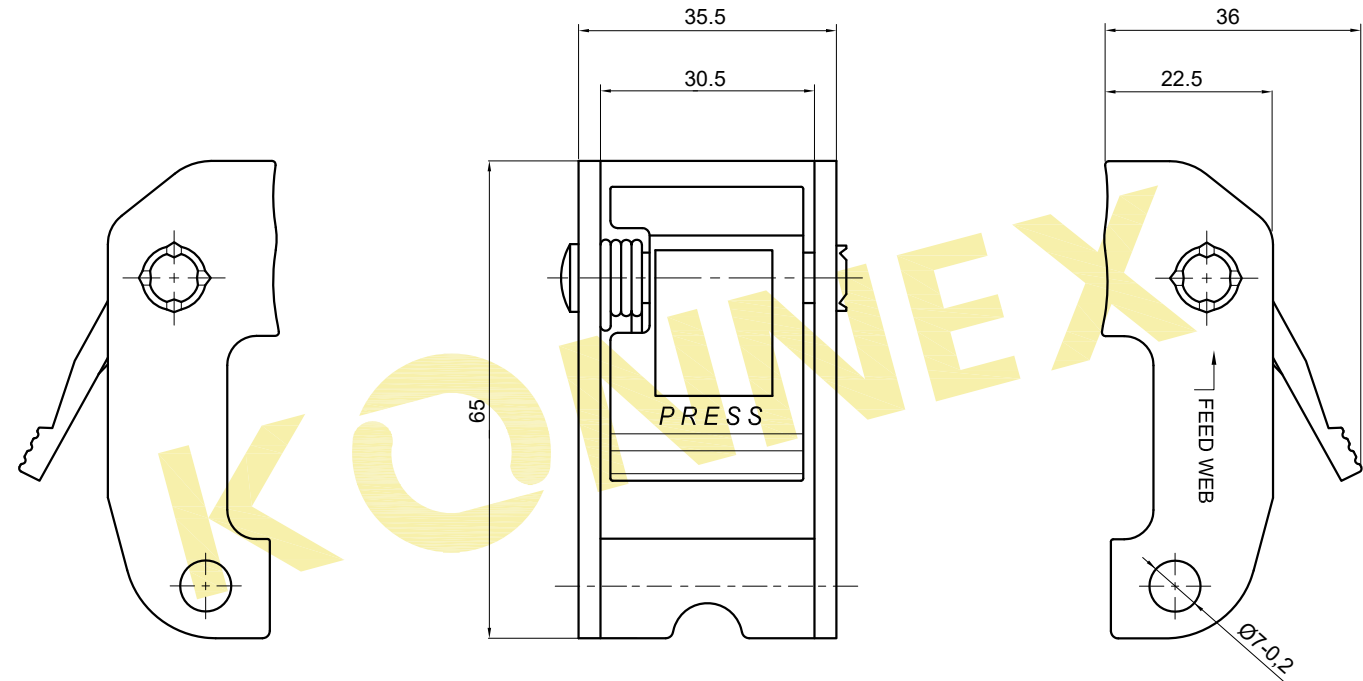

Technical requirements:

1. Breaking strength (BS): 10 kN
2. No cracking pitting rust spot and scratch
3. Tested according: EN ISO 9227 NSS
4. Tested according: DIN EN 12195-2

Product Code: 70AQ075		Surface Requirement: Zinc plating	Tolerance: ---	Projection: 	Scale: ---	Weight: ---g						
					Material: Steel							
		Date	Name	Part Name:								
		2015.04.08	QWZ	Klemmschloss 25mm - 10kN								
		Check		Cam buckle 25mm - 10kN								
		Approve		Drawing No:								
				70AQ075								
				<table border="1"> <tr> <td>Page</td> <td>Rev</td> <td>Format</td> </tr> <tr> <td>1</td> <td></td> <td>A4</td> </tr> </table>			Page	Rev	Format	1		A4
Page	Rev	Format										
1		A4										
ECN	No	Content of Change	Date	Name	Original Drawing: ---	Replaces: ---						
						Replaced by: ---						

